

mapes
ARCHITECTURAL PANELS

Manufacturer of Laminated
Architectural Panels



panels

Installation Instructions / Molding Details

www.mapes.com

INSTALLATION INSTRUCTIONS FOR MAPES VENEER PANELS

General Instructions

- Mapes veneer panels are designed to be glazed into moldings or framing systems which will allow proper thermal expansion and contraction.
- Panel edges must be protected against moisture intrusion from both exterior infiltration and wall cavity condensation.
- Panels should be installed over studs or furring 24" o/c or less, using a 3/8" bead of high-grade adhesive applied along all framing surfaces.
- A vapor barrier exceeding 6 mil shall be applied to the warm side of the wall.
- Ventilation of the stud space may be required by design or local code requirements.
- Panels can be field cut using a carbide blade. Panels should be sized 3/16" smaller than the module required to allow for thermal expansion/contraction. Cutting burrs should be removed prior to insertion in the moldings.
- Mechanical face fasteners should be avoided (excluding soffit applications).
- Panels must be stored in flat, dry conditions.
- Remove protective plastic masking immediately upon receipt of panels.

Extruded Veneer Moldings

- Consideration for the entire layout should be made prior to installation.
- Establish a horizontal baseline at the foundation. Set panels and molding with a plumb line and level.
- Attach molding with #8 x 1/2" self tapping screws placed no greater than 24" o/c.
- Place an adequate amount of approved sealant into the extrusion pocket to ensure complete edge coverage of the panel. Sealant should squeeze out of both front and back of panel surfaces.
- Vertical moldings should pass through the horizontal moldings. Joints must be sealed.

Sealants and Adhesives

Adhesives - Titebond construction adhesive, 3M VHB structural glazing tape, HB Fuller Power Grip, or Macco-Liquid Nail.

Sealants - Tremco ProGlaze or Spectrum 2, Dow 795, GE Silglaze.

Applications

Wall Facing

- Minimum 6 mil vapor barrier applied to warm side of wall.
- Fill molding channel with sealant prior to panel insertion.
- Shim stud or furring to level wall surface.
- Apply adhesive within 15 minutes of panel application to ensure proper bond.

Soffit Application

- Similar to wall facing instruction.
- Mechanical fasteners can be applied 24" o/c if required.

Window Opening

- Fill molding channel with sealant prior to panel insertion.
- Molding is required on all 4 sides of the opening.
- Panels should be blocked to allow for thermal expansion and contraction.
- Wall cavity should have a minimum 6 mil vapor barrier installed on the warm side.

Please consult the factory for special considerations. Details are available on www.mapes.com.

CAUTION – Excessive/rapid heat buildup in shadowbox applications can lead to panel deformation and system failure. Use of Mapes panels in a shadowbox application is not recommended without independent system testing. Consult factory prior to panel installation.

Failure to properly install and seal Mapes panels in accordance with all installation instructions will void all warranties and forfeit all buyer remedies.

scale 1/2" = 1"

1/4" MOLDINGS: VENEER PANELS

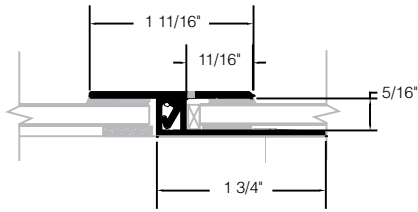

Two Piece Divider
MIN-66 receptor & MIN-69 divider

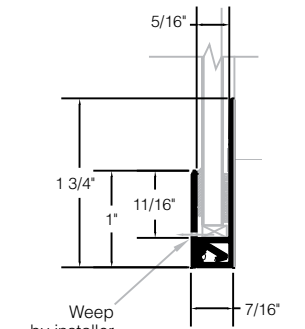

Two Piece Cap
MIN-66 receptor & MIN-67 cap

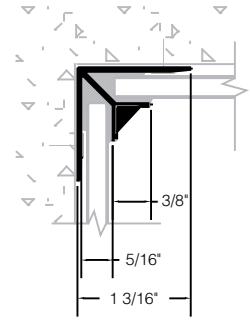

Inside Corner
A-1022

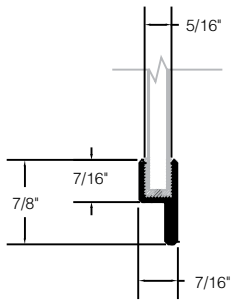

Add-on / Projected Sash
MW-15936

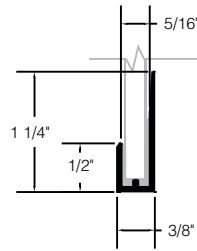

One Piece Cap
MIN-39

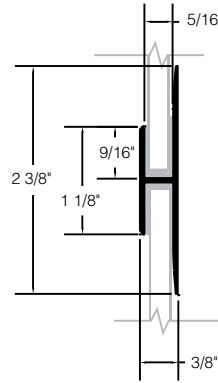

One Piece Divider
MIN-40

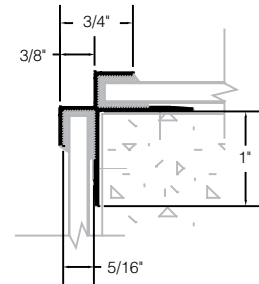

Outside Corner
MIN-41

1" MOLDINGS & MAPES-R PANELS

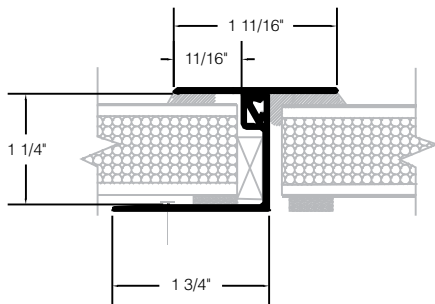

Two Piece Divider
MIN-68 receptor & MIN-69 divider

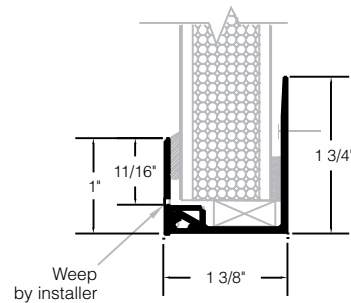

Two Piece Cap
MIN-68 receptor & MIN-67 cap

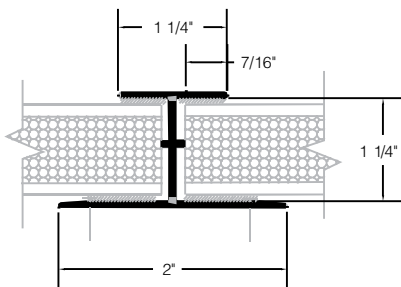

One Piece Divider
MW-22943

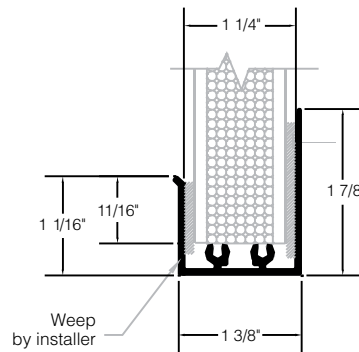

One Piece Cap
MW-22944

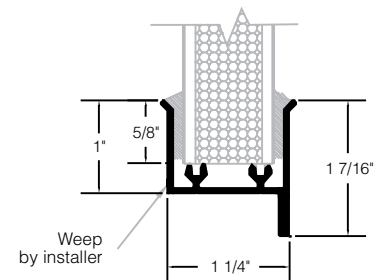

Add-on / Projected Sash
MW-16610

IMPORTANT! GIVE TO INSTALLER

RECOMMENDED PANEL INSTALLATION DETAIL

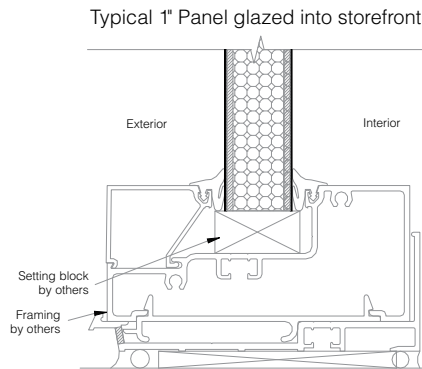

- Panels must be sealed against water penetration per framing manufacturers recommendations.
- Panels must be installed using flexible setting blocks providing at least 1/4" around the panel perimeter to allow for thermal expansion.
- Framing system must be weeped per manufacturers recommendations. CAUTION – Moisture on exposed panel edges can cause significant deterioration of panel finish and performance.
- Do not clean panels with any cleaner containing acid or allow any type of acid to come in contact with the porcelain finish. Use of brick wash is cautioned. Panel should be test washed prior to use.
- Protective film (if applicable) must be removed immediately upon receipt of panels.

PROPER CAULKING TECHNIQUES FOR 1/4" PANELS

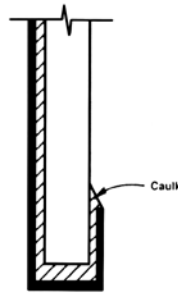

1. Apply caulking to molding channel prior to insertion of panel.
2. Insert Panel until caulking squeezes out both front and rear.
3. Face caulk as required.
4. Clean up can be accomplished using Mineral Spirits or Naptha.
5. Panels should be supported with applied mastic 24" on center at rear.

STANDARD VENEER APPLICATION WITH APPLIED STOPS

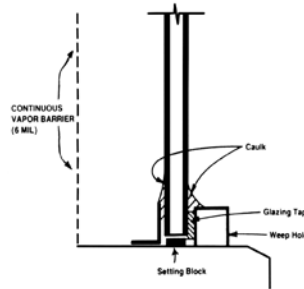

- Panel should be sealed interior & exterior with permanently elastic Silicone Caulking.
- Panel should be blocked.
- Applied stop should be weeped to the exterior.
- Veneer panels with loose insulation behind them should be back-caulked in conjunction with a minimum 6 mil vapor barrier to eliminate condensation formation.

Important for Both Installation Techniques: A continuous 6 mil vapor barrier is required to prevent condensation within the wall cavity.

VENEER PANEL INSTALLATION INSTRUCTIONS

FURRING WALLS:

- Install vertical furring strips, not less than 1" x 2" behind all proposed vertical extruded aluminum moldings. Vertical furring strips shall be spaced not more than 2' 0" o/c. All furring shall be anchored with rustproof masonry nails or non-ferrous expansion type rivets, spaced 16" – 24" on center.
- Install horizontal furring in a like manner between the vertical strips at all panel joints. Important: Leave adequate space (1" min.) between all vertical & horizontal furring to allow wall to "breathe" & to prevent entrapped moisture from condensing upon panel surfaces. (See sketch) Also, vapor barrier is required.
- Plumb all furring with the use of shims, if necessary.

INSTALLING VENEER PANELS:

- Install vertical corner molding along furring strip.
- Install the lowest horizontal molding parallel to datum line established with transit or water level.
- Install horizontal molding above lowest horizontal molding.
- Run light caulking bead along moldings installed. Insert panel after applying adhesive to wall or pieces of furring. Leave about 1/16" expansion space at edges of panel.
- Cut vertical molding for fourth side of panel, caulk and install.
- Install adjacent horizontal panels in row begun. Repeat applicable steps to completion.

REMARKS

- Plan your layout carefully to avoid working into difficult locations and to effect maximum economy in fitting and cutting.
- Panels should be cut from the back & smooth burred edges.
- Apply construction adhesive on wall or on pieces of furring strip securely anchored to wall.
- The entire system must be properly sealed against moisture for the warranty to remain valid.

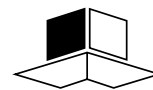
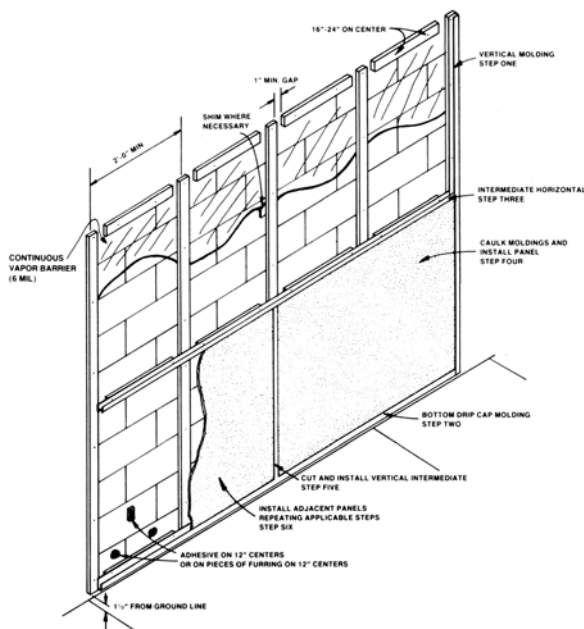

mapes
ARCHITECTURAL PANELS

Mapes Panels, LLC
2929 Cornhusker Hwy / Lincoln, NE 68504
800-228-2391 / 800-737-6756 fax
sales@mapes.com / www.mapes.com